

VASI supplied hydraulic pullers are designed for tough industrial applications and are available in sizes from 5 to 44 ton.

The rugged design will make this a workhorse for many years to come. The benefits of hydraulic pullers, compared with mechanical ones, are many; the most important is a non rotating piston / press head. This allows the user to carry out the pull safely without the risk of slipping.

- Rugged design.
- Safe and stable pull operations as piston is non rotating.
- Self aligning.



The smaller sizes, 5 ton and 10 ton, are equipped with special mechanics which self centers the arms. The arms will therefore always adapt to the diameter of the object and have the best possible grip and handling. All REHOBOT pullers are furthermore self aligning and have an extra long stroke. The pull depth can easily be adjusted by moving the arm attachments.

The hydraulic pullers can be used with 2 or 3 arms (except for AH450 - only 3 arms). Different lengths of arms are available as accessories.

They are also sold as stand alone units without the hydraulics

Contact us to choose a suitable pump for your demands.

Name	Item code	Capacity kN (t)	Max. opening mm	Stroke volume cm ³	Weight kg
AH50	37143	49 (5)	250	165	6.4
AH110	37151	111 (11)	400	485	15.1
AH200	37159	200 (20)	500	1032	23.7
AH450	37163	450 (46)	700	1272	76.1

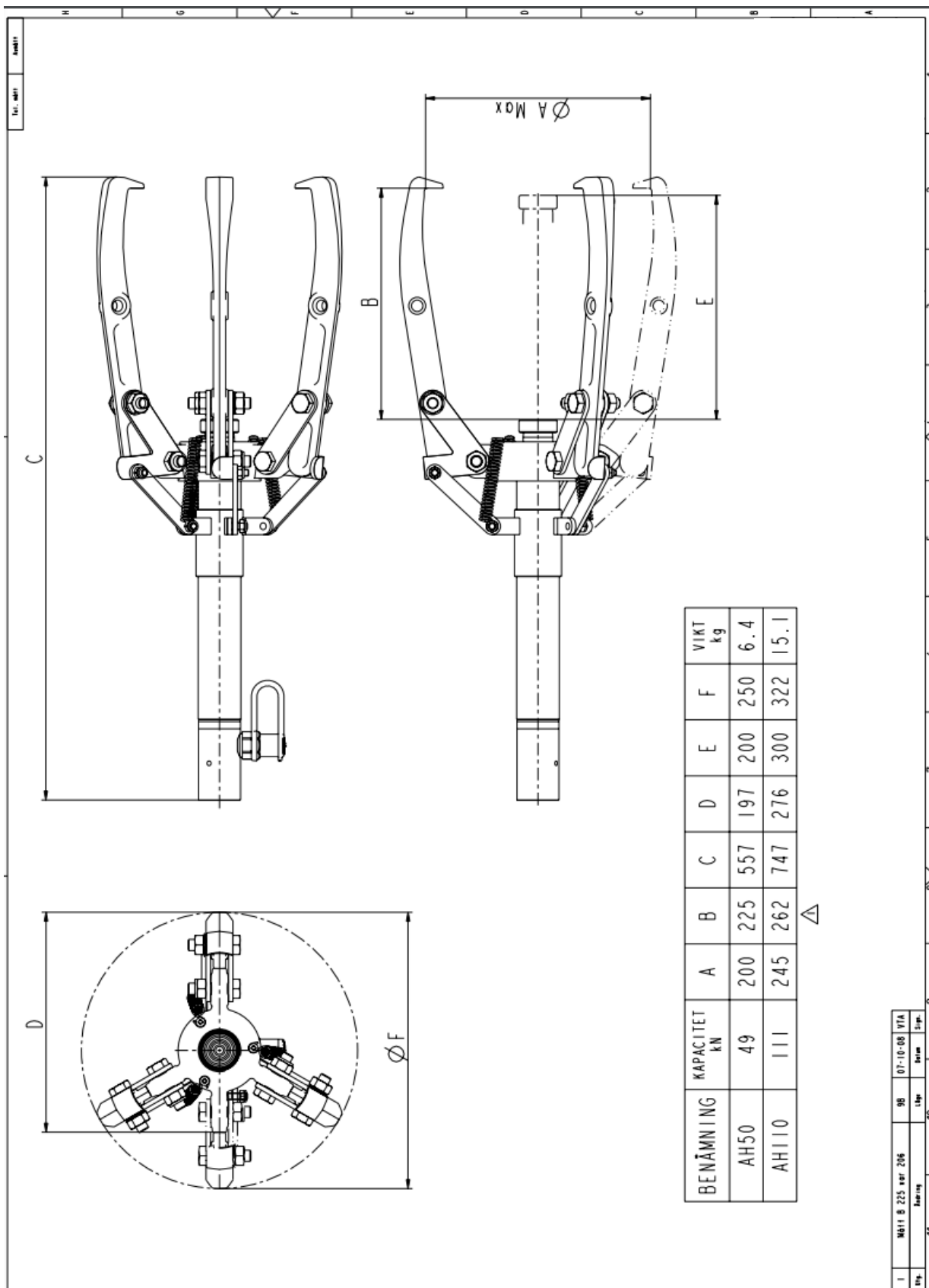

1	98	07-10-08	VIA
2	98	07-10-08	VIA
3	98	07-10-08	VIA
4	98	07-10-08	VIA
5	98	07-10-08	VIA
6	98	07-10-08	VIA
7	98	07-10-08	VIA
8	98	07-10-08	VIA
9	98	07-10-08	VIA
10	98	07-10-08	VIA
11	98	07-10-08	VIA

THIS DRAWING IS THE PROPERTY OF VASI. IT IS NOT TO BE REPRODUCED OR TRANSMITTED IN ANY FORM OR BY ANY MEANS, ELECTRONIC OR MECHANICAL, INCLUDING PHOTOCOPYING, RECORDING, OR BY ANY INFORMATION STORAGE AND RETRIEVAL SYSTEM.

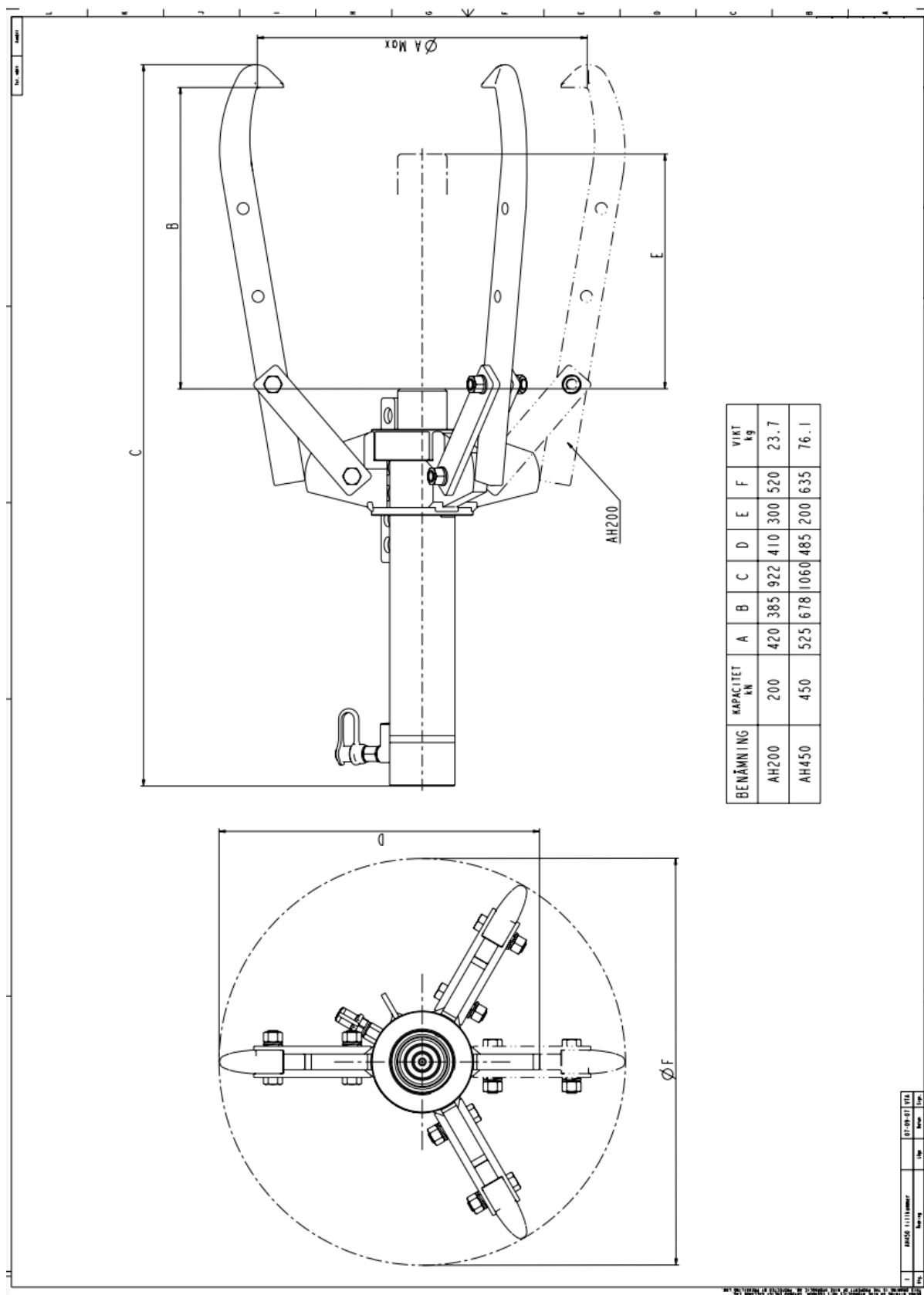

1	1	1	1	1	1	1	1	1
1	1	1	1	1	1	1	1	1

© 2011 VASI. Alla iakttagelser och användningar av denna produkt är förbehållna för VASI. Alla rättigheter förbehållna.