

CFC cylinders are real all-round cylinders. They come in a wide range of capacities and strokes. The CFC cylinders' compact design provides high force in a small package. The cylinders are fitted with rod end scrapers to keep dirt from entering the cylinder and ensuring proper function in harsh environments.

- 5-95 ton capacity and 27-362 mm stroke length.
- Wiper polyurethane, positioned so that dirt can not penetrate between the piston rod and cylinder.
- Corrosion protection - plated piston rod and electroplated cylinder.
- Collar mounting threads as standard.
- Optional base mounting holes at the bottom of the cylinder.

Models with 5-25 ton capacity can be fitted with adapters for mounting of accessories such as pressure heads or chains, extending the use of the cylinder.



Name	Item code	Working press. MPa	Capacity kN (t)	Stroke mm	Stroke volume cm ³	Diameter mm	Height mm	Weight kg
CFC51A	40184	70	49 (5)	27	19	38	110	0.8
CFC53A	40186	70	49 (5)	77	55	38	165	1.2
CFC55A	40188	70	49 (5)	127	90	38	216	1.5
CFC57A	40190	70	49 (5)	181	128	38	273	1.9
CFC59A	40192	70	49 (5)	232	165	38	324	2.2
CFC101	40235	70	111 (11)	25	40	57	90	1.5
CFC102	40237	70	111 (11)	54	86	57	121	2
CFC104	40239	70	111 (11)	105	167	57	171	2.7
CFC106	39849	70	111 (11)	155	247	57	247	4
CFC108	39850	70	111 (11)	206	328	57	298	4.6
CFC1010	39851	70	111 (11)	257	409	57	349	5.3
CFC1012	39852	70	111 (11)	305	485	57	400	6
CFC1014	39853	70	111 (11)	356	566	57	451	6.8

Name	Item code	Working press. MPa	Capacity kN (t)	Stroke mm	Stroke volume cm ³	Diameter mm	Height mm	Weight kg
CFC151	40264	70	166 (17)	25	59	70	124	3
CFC152	40266	70	166 (17)	51	121	70	149	3.5
CFC154	40268	70	166 (17)	101	240	70	200	4.5
CFC156	39881	70	166 (17)	152	361	70	272	6.5
CFC158	39882	70	166 (17)	203	482	70	322	7.5
CFC1510	39883	70	166 (17)	254	603	70	373	8.5
CFC1512	39884	70	166 (17)	305	725	70	424	9.5
CFC1514	39885	70	166 (17)	356	846	70	475	10.9
CFC251	39940	70	232 (24)	25	83	85	140	5.1
CFC252	39941	70	232 (24)	51	169	85	165	5.9
CFC254	39942	70	232 (24)	101	335	85	216	7.7
CFC256	39943	70	232 (24)	159	528	85	273	9.7
CFC258	39944	70	232 (24)	209	694	85	324	11.5
CFC2510	39945	70	232 (24)	260	863	85	375	13.3
CFC2512	39946	70	232 (24)	311	1032	85	426	15
CFC2514	39947	70	232 (24)	362	1201	85	476	17
CFC502	40292	70	496 (51)	53	376	127	176	16
CFC504	40294	70	496 (51)	104	737	127	227	19
CFC506	40296	70	496 (51)	159	1127	127	282	23
CFC5013	40298	70	496 (51)	337	2389	127	460	35
CFC756	40344	70	727 (74)	155	1610	146	282	30
CFC7513	40345	70	727 (74)	333	3459	146	492	48
CFC1006	40388	70	929 (95)	168	2230	175	359	54
CFC10010	40389	70	929 (95)	260	3451	175	450	65

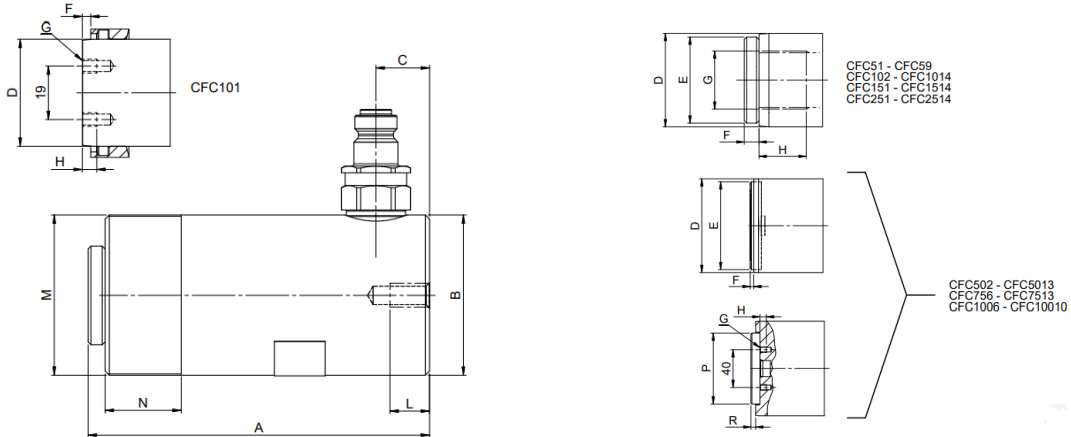
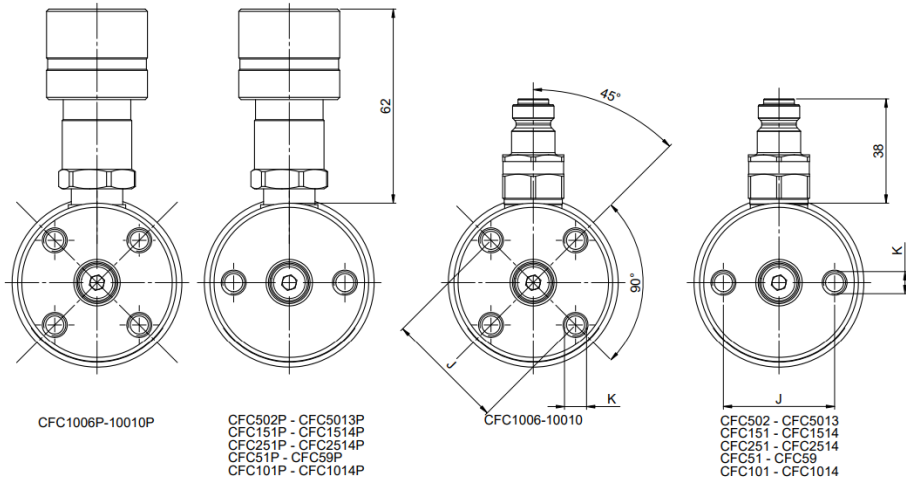

Modell / Model	Max arbetstryck / Max working pressure (MPa)	Kapacitet / Capacity (kN)	Slaglängd / Stroke (mm)	Kolvarea / Piston area (cm ²)	Slagvolym / Stroke volume (cm ³)	A (mm)	Ø B (mm)	C (mm)	Ø D (mm)	Ø E (mm)	F (mm)	G	H (mm)	J (mm)	K	L (mm)	M	N (mm)	Ø P (mm)	R (mm)	Vikt / Weight (kg)
CFC51	70	49	27	7.1	19	110	38	19	25.4	25	6	3/4"-16 UNF	16	25	1/4"-20 UNC	14	1 1/2"-16 UN	29	---	---	0.8
CFC53	70	49	77	7.1	55	165	38	19	25.4	25	6	3/4"-16 UNF	16	25	1/4"-20 UNC	14	1 1/2"-16 UN	29	---	---	1.2
CFC55	70	49	127	7.1	90	218	38	19	25.4	25	6	3/4"-16 UNF	16	25	1/4"-20 UNC	14	1 1/2"-16 UN	29	---	---	1.6
CFC57	70	49	181	7.1	128	273	38	19	25.4	25	6	3/4"-16 UNF	16	25	1/4"-20 UNC	14	1 1/2"-16 UN	29	---	---	1.9
CFC59	70	49	232	7.1	165	324	38	19	25.4	25	6	3/4"-16 UNF	16	25	1/4"-20 UNC	14	1 1/2"-16 UN	29	---	---	2.2
CFC101	70	111	25	15.9	40	90	57	19	38	35	3	10-24 UN	7	40	5/16"-18 UNC	12	2 1/4"-14 UN	27	---	---	1.5
CFC102	70	111	54	15.9	86	121	57	19	38	35	6	1"-8 UNC	21	40	5/16"-18 UNC	12	2 1/4"-14 UN	27	---	---	2
CFC104	70	111	105	15.9	167	171	57	19	38	35	6	1"-8 UNC	21	40	5/16"-18 UNC	12	2 1/4"-14 UN	27	---	---	2.7
CFC106	70	111	155	15.9	247	237	57	19	38	35	6	1"-8 UNC	22	40	5/16"-18 UNC	12	2 1/4"-14 UN	27	---	---	4
CFC108	70	111	206	15.9	328	297	57	19	38	35	6	1"-8 UNC	22	40	5/16"-18 UNC	12	2 1/4"-14 UN	27	---	---	4.6
CFC1010	70	111	257	15.9	409	349	57	19	38	35	6	1"-8 UNC	22	40	5/16"-18 UNC	12	2 1/4"-14 UN	27	---	---	5.3
CFC1012	70	111	305	15.9	485	400	57	19	38	35	6	1"-8 UNC	22	40	5/16"-18 UNC	12	2 1/4"-14 UN	27	---	---	6
CFC1014	70	111	356	15.9	566	451	57	19	38	35	6	1"-8 UNC	22	40	5/16"-18 UNC	12	2 1/4"-14 UN	27	---	---	6.8
CFC151	70	166	25	23.8	59	124	70	19	48	38	10	1"-8 UNC	17	48	3/8"-16 UNC	13	2 3/4"-16 UN	30	---	---	3
CFC152	70	166	51	23.8	121	149	70	19	48	38	10	1"-8 UNC	22	48	3/8"-16 UNC	13	2 3/4"-16 UN	30	---	---	3.5
CFC154	70	166	101	23.8	240	200	70	19	48	38	10	1"-8 UNC	22	48	3/8"-16 UNC	13	2 3/4"-16 UN	30	---	---	4.5
CFC156	70	166	152	23.8	361	272	70	25	48	38	10	1"-8 UNC	25	48	3/8"-16 UNC	13	2 3/4"-16 UN	30	---	---	6.5
CFC158	70	166	203	23.8	482	322	70	25	48	38	10	1"-8 UNC	25	48	3/8"-16 UNC	13	2 3/4"-16 UN	30	---	---	7.5
CFC1510	70	166	253	23.8	603	373	70	25	48	38	10	1"-8 UNC	25	48	3/8"-16 UNC	13	2 3/4"-16 UN	30	---	---	8.5
CFC1512	70	166	305	23.8	725	424	70	25	48	38	10	1"-8 UNC	25	48	3/8"-16 UNC	13	2 3/4"-16 UN	30	---	---	9.5
CFC1514	70	166	356	23.8	846	475	70	25	48	38	10	1"-8 UNC	25	48	3/8"-16 UNC	13	2 3/4"-16 UN	30	---	---	10.9
CFC251	70	232	25	33.2	83	140	85	22	60	50	10	1 1/2"-16 UN	25	59	1/2"-13 UNC	19	3 5/16"-12 UN	49	---	---	5.1
CFC252	70	232	51	33.2	169	165	85	22	60	50	10	1 1/2"-16 UN	25	59	1/2"-13 UNC	19	3 5/16"-12 UN	49	---	---	5.9
CFC254	70	232	101	33.2	335	216	85	22	60	50	10	1 1/2"-16 UN	25	59	1/2"-13 UNC	19	3 5/16"-12 UN	49	---	---	7.7
CFC256	70	232	159	33.2	523	273	85	22	60	50	10	1 1/2"-16 UN	25	59	1/2"-13 UNC	19	3 5/16"-12 UN	49	---	---	9.7
CFC258	70	232	209	33.2	694	324	85	22	60	50	10	1 1/2"-16 UN	25	59	1/2"-13 UNC	19	3 5/16"-12 UN	49	---	---	11.3
CFC2510	70	232	269	33.2	863	373	85	22	60	50	10	1 1/2"-16 UN	25	59	1/2"-13 UNC	19	3 5/16"-12 UN	49	---	---	13.3
CFC2512	70	232	311	33.2	1032	426	85	22	60	50	10	1 1/2"-16 UN	25	59	1/2"-13 UNC	19	3 5/16"-12 UN	49	---	---	15
CFC2514	70	232	362	33.2	1201	476	85	22	60	50	10	1 1/2"-16 UN	25	59	1/2"-13 UNC	19	3 5/16"-12 UN	49	---	---	17
CFC502	70	496	53	70.9	376	176	127	33	80	75	3	M6	8	95	M12	19	5"-12 UN	55	76	6.5	16
CFC504	70	496	104	70.9	737	227	127	33	80	75	3	M6	8	95	M12	19	5"-12 UN	55	76	6.5	19
CFC506	70	496	159	70.9	1127	282	127	33	80	75	3	M6	8	95	M12	19	5"-12 UN	55	76	6.5	23
CFC5013	70	496	337	70.9	2389	460	127	33	80	75	3	M6	8	95	M12	19	5"-12 UN	55	76	6.5	35
CFC756	70	727	155	103.9	1610	282	146	29	100	75	5	M6	8	---	---	---	5 3/4"-12 UN	44	77	4.5	30
CFC7513	70	727	333	103.9	3459	492	146	29	100	75	5	M6	8	---	---	---	5 3/4"-12 UN	44	77	4.5	48
CFC1006	70	929	168	132.7	2230	359	175	41	100	75	5	M6	8	140	3/4"-10 UNC	24	6 7/8"-12 UN	54	77	4.5	54
CFC10010	70	929	260	132.7	3451	450	175	41	100	75	5	M6	8	140	3/4"-10 UNC	24	6 7/8"-12 UN	54	77	4.5	65